

Kbiosystems blowdown evaporators for sample concentration.

Kbiosystems Porvair evaporators are designed to remove the traditional laboratory 'bottleneck' of solvent evaporation from microplates prior to analysis or reconstitution in storage buffer. These evaporators give significant throughput advantages to laboratories looking to optimise microplate sample preparation productivity. Faster than centrifugal evaporation, significant increases in sample throughput are achieved through advanced evaporator head technology and an innovative manifold design, which directly injects heated nitrogen into each individual well of the microplate simultaneously. The evaporators have been designed to be simple to install, operate and maintain. Installation requires only connection to a gas supply or cylinder and mains electricity. Safety of operation is ensured as the CE marked compact units fit into all fume cupboards. Not suitable for high boiling solvents such as DMSO and water.

The UltravapMINI is purpose designed for low usage research and development departments where low numbers of individual plates or vials need drying.

Simple to operate and maintain. Installation requires only connection to a gas supply and standard mains socket. With manual control of the needle depth, gas temperature and flow rate, it allows fine control and quicker drying times than other standard methods.



Order Code: RBX-10013



Order Code: RBX-10051

UltravapGEMINI is a two-position nitrogen blowdown concentrator and evaporator for the budget-conscious laboratory. Kbiosystems Porvair nitrogen blowdown evaporators have for many years been a central resource for sample preparation in the laboratory. The ability to safely and easily remove organic and chromatographic solvents from samples is vitally important. Samples can be dried down and re-constituted in a more suitable solvent, or they may simply be concentrated before analysis to increase sensitivity.

The nitrogen blowdown process is ideal for lower boiling point organic solvents such as methanol, dichloromethane, hexane and acetonitrile. The robust design of the Gemini brings together for the first time in our range two individually temperature-regulated evaporation positions with a wide choice of head styles and configurations. This means you can dry down a 96-well deep well plate at the same time as 48 HPLC vials. This breakthrough in productivity will speed up the evaporation bottleneck in your laboratory, increase the sensitivity of your analyses and quicken sample processing times.

- Quicker dry down times than vacuum oven processes
- Tests have shown that the MiniVap® can evaporate 500µl of methanol in less than 6 minutes
- Designed for any ANSI/SLAS 96-well plate
- 24, 48, 96 flow heads available

- Designed for any ANSI/SLAS 96-well plate
- 24 vial head now available
- Simple to install and operate
- Easy adjustments of temperature, gas flow rates and needle depth into the wells
- Compact footprint – fits all standard fume cupboards

sales@wildcat-ls.eu
www.wildcatls.com
+44 (0) 1778 788007

General assembly.

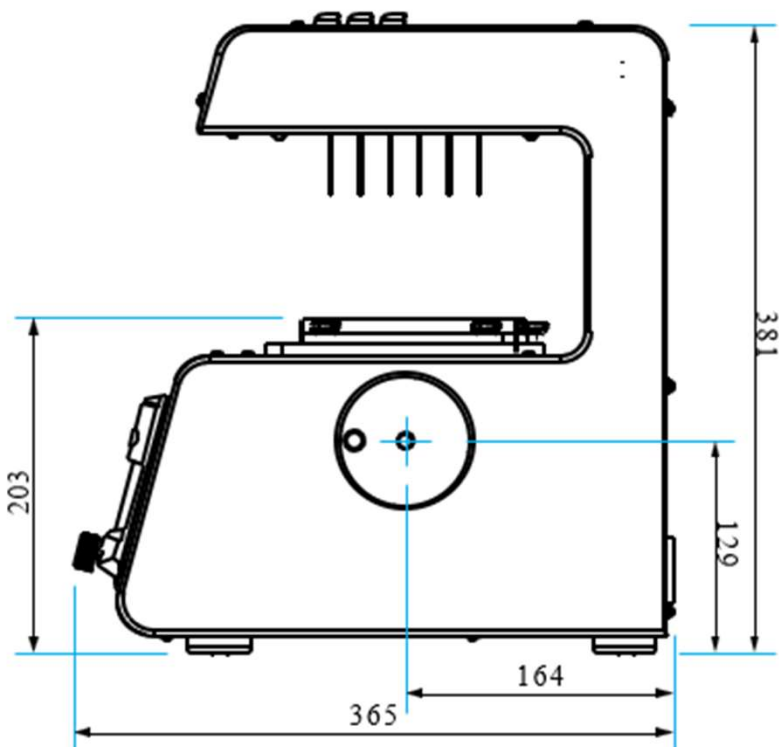
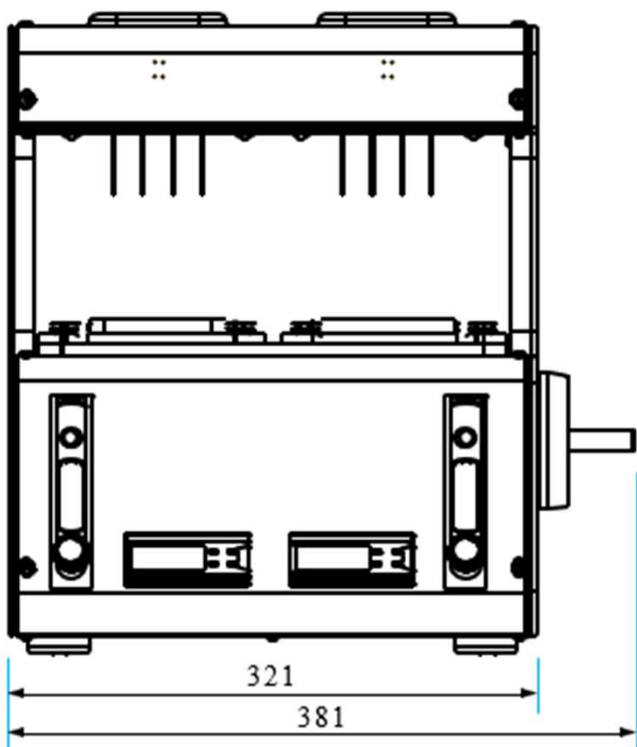
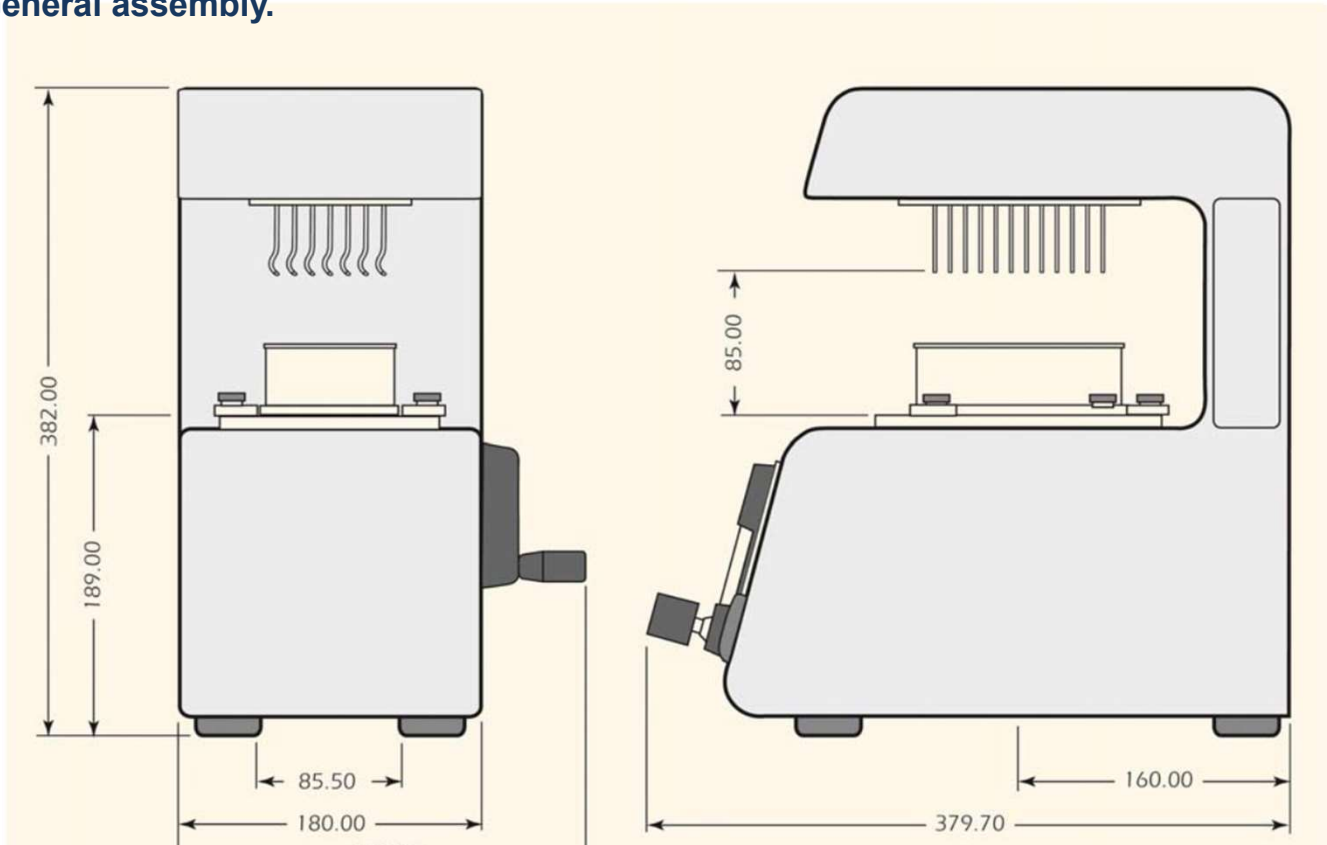

Key Features:

- Easy to program temperature settings
- Able to use multiple plastic ware manufactures plates across applications. Engineered with robustness in mind
- Gas heat ambient to 60°C
- Flow rate of gas up to 70 L/min, **note heater inactive below 35L/min
- 24, 48 , 96 needle process heads
- Simple manual height adjustment

Operational Requirements:

- 110 / 220vac, 50/60Hz,
- 10Amp socket outlet, system supplied with IEC lead
- The unit requires a gas supply rated to min 5.5bar max 6.5bar
**flow rated to 80LPM for MINI and 160LPM for GEMINI
- Weights Approx. <10 kgs
- 380mm L x 241mm W x 382mm H – MINI
- 365mm L x 381mm W x 381mm H - GEMINI