

**Kbiosystems Sealing Series of automated and semi automated systems offer the ideal entry level automation laboratories require for a reliable, consistent plate and tube closing.**

The Ultraseal PRO unit is an automated heat applied micro plate and tube rack sealer for sealing tall plate racks and tubes up to 47mm base to top height. The unit uses a roll of surface modified aluminium or plastic film approx. 78mm wide and 610m long, the roll is positioned to the rear of the sealing section via a removable stand, using a total inline method the film is pulled through the main unit, cut to between 125mm and 130mm in length and then applied to the plate top surface to create the seal between plate and film.

Offering complete versatility, the sealer Series will work with a wide range of plates, tube racks and custom applications shallow and deep well formats, and custom moldings.

Our latest range of seals support polystyrene, polypropylene and CoC & CoP plate formats with a range of film substrates please contact us for further details.

Constant time and pressure lead the way in sealing techniques, kbiosystems developed the first fully automated production sealers way back in 1994 and still are considered the premier application specialist amongst users and integrators alike.

System operation is designed to efficiently apply a heat activated sealing film to a micro well plate or tube rack top surface. By pulling and maintaining control of a reel of film cutting to the desired length and by means of heat and time based variables apply the film to achieve the seal. The unit is both pneumatically and electrically operated and hence will require both supplies to be readily available.

Gas Purge option allows the user to lay a heavy gas coating to the well surface prior to sealing, this will then once sealed offer a protective barrier to the air void often left between sample and seal, with the gas laid prior to sealing an oxygen reduce or virtually oxygen free space environment can be achieved.



Order Code: RBX-10069

General assembly.

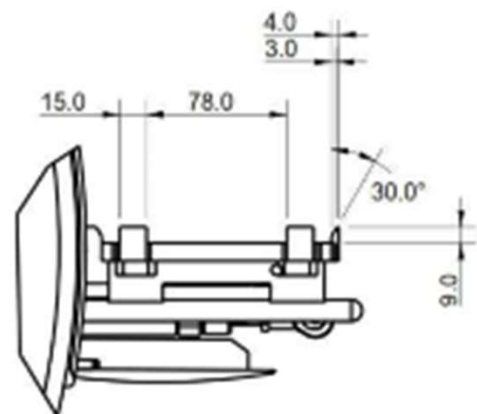
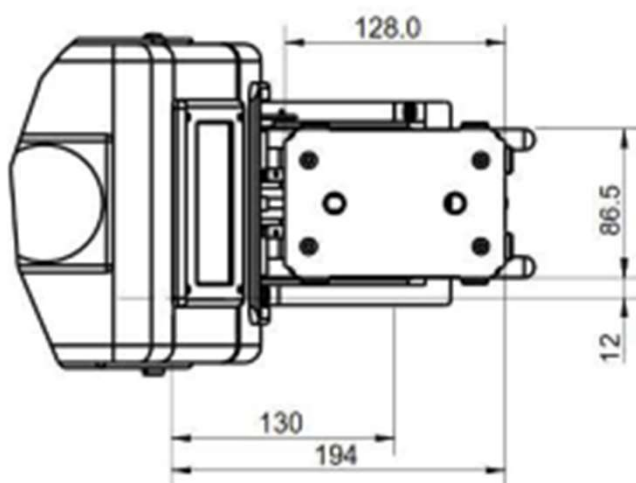
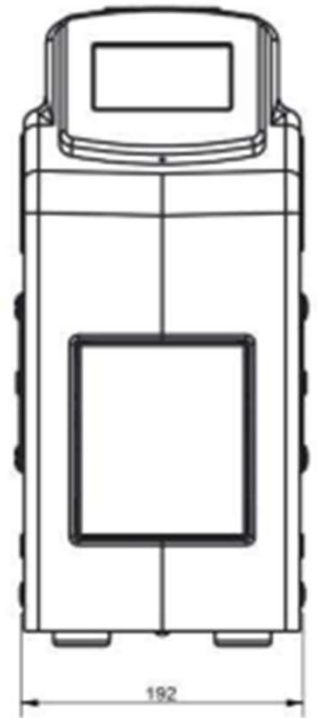
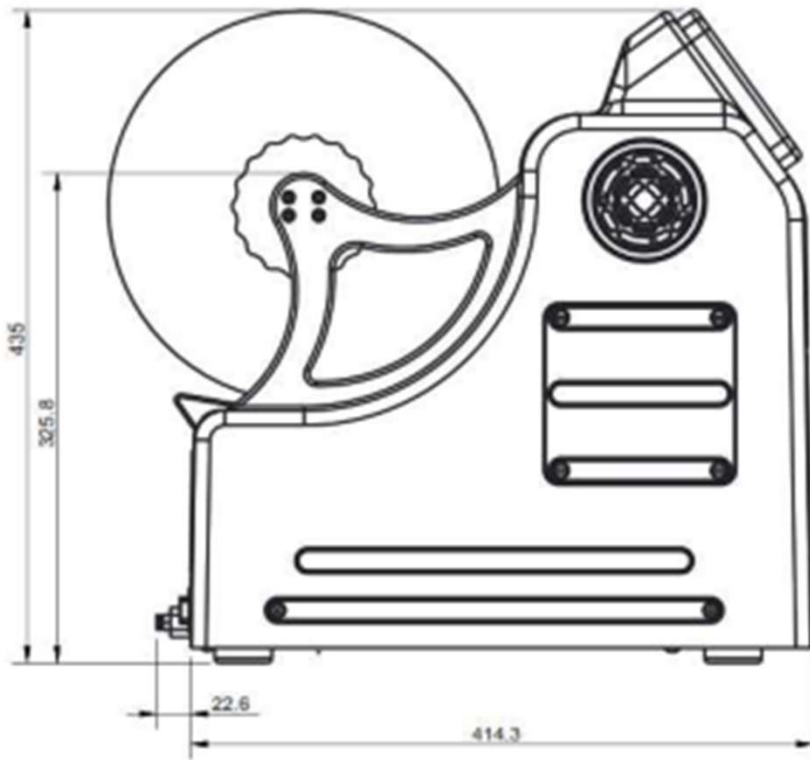

## Key Features:

- Easy to program and operator and integrator friendly
- Able to use multiple plastic ware manufactures plates across applications. Engineered with robustness in mind
- Heat Sealer ambient to 199°c
- Foil Seals
- Optical Seals
- Gas Permeable seals
- Automatic cut and application of seals
- Shuttle extension module for greater access (option) +35mm
- Auto link to Scorpion Stacker
- Plate height range 7 to 47mm

## Operational Requirements:

- 110 / 220vac, 50/60Hz, 6Amp socket outlet, system supplied with IEC lead
- The unit requires a supply rated to min 5.5bar max 6.5bar 50 litres per min.
- Weights Approx. <15 kgs
- 630mm L x 192mm W x 435mm H (Inc. film roll)
- 3m RS232 (3 wire 2,3 and 5 connection non twisted)  
Supplied with API communication protocol
- Requires Heavy gas supply 6mm pipe with 0 to 10 PSI control,
- \*\*additional gas safe monitoring will be needed or suitable fume hood.\*\*